

Spring series LFP Battery

AI-W5.1

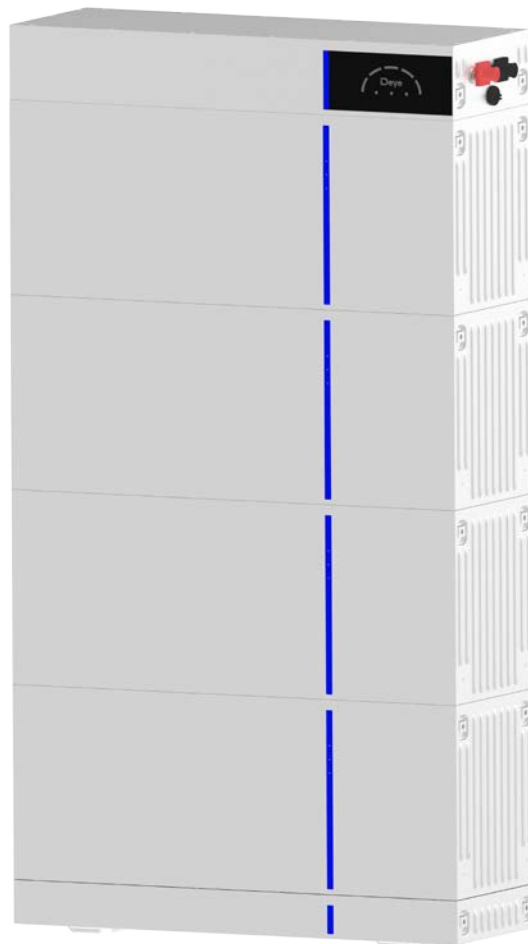

About This Manual

The manual mainly describes the product information, guidelines for installation, operation, and maintenance. The manual cannot include complete information about the solar photovoltaic-energy storage hybrid system.

How to Use This Manual

Read the manual and other related documents before performing any operation on the battery. Documents must be stored carefully and be always available.

Contents may be periodically updated or revised due to product development. The information in this manual is subject to change without notice. The latest manual can be acquired via service-ess@deye.com.cn (www.deyeess.com).

1 Safety Introductions



Reminding

- 1) It is very important and necessary to read the user manual carefully (in the accessories) before installing or using battery. Failure to do so or to follow any of the instructions or warnings in this document can result in electrical shock, serious injury, or death, or can damage battery, potentially rendering it inoperable.
- 2) If the battery is stored for long time, it is required to charge them every six months, and the SOC should be no less than 50%.
- 3) Battery needs to be recharged within 48 hours after fully discharged.
- 4) Do not expose cable outside.
- 5) All the battery terminals must be disconnected for maintenance.
- 6) Please contact the supplier within 24 hours if there is something abnormal.
- 7) Do not use cleaning solvents to clean battery.
- 8) Do not expose battery to flammable or harsh chemicals or vapors.
- 9) Do not paint any part of Battery, include any internal or external components.
- 10) Do not connect battery with PV solar wiring directly.
- 11) The warranty claims are excluded for direct or indirect damage due to items above.
- 12) Any foreign object is prohibited to insert into any part of battery.



Li-ion





Warning

1.1 Before Connecting

- 1) After unpacking, please check product and packing list first, if product is damaged or lack of parts, please contact with the local retailer.
- 2) Before installation, be sure to cut off the grid power and make sure the battery is in the turned-off mode.
- 3) Wiring must be correct, do not mistake the positive and negative cables, and ensure no short circuit with the external device.
It is prohibited to connect the battery and AC power directly.
- 4) Please ensure the electrical parameters of battery system are compatible to related equipment.
- 5) Keep the battery away from water and fire.

1.2 In Using

- 1) If the battery system needs to be moved or repaired, the power must be cut off and the battery is completely shut down.
- 2) It is prohibited to connect the battery with different type of Battery.
- 3) It is prohibited to put the batteries working with faulty or incompatible inverter.
- 4) It is prohibited to disassemble the battery.
- 5) In case of fire, only dry fire extinguishers can be used. Liquid fire extinguishers are forbidden.
- 6) Please do not open, repair, or disassemble the battery except staffs from DEYE or authorized by DEYE. We do not undertake any consequences or related responsibility which because of violation of safety operation or violating of design, production, and equipment safety standards.

2 Introduction

- ◇ AI-W5.1 lithium iron phosphate battery is one of new energy storage products developed and produced by DEYE, it can be used to support reliable power for various types of equipment and systems.
- ◇ AI-W5.1 is especially suitable for application scene of high power, limited installation space and long cycle life.
- ◇ AI-W5.1 has built-in BMS battery management system, which can manage and monitor cells information including voltage, current and temperature. What's more, BMS can balance cells charging and discharging to extend cycle life.
- ◇ Multiple batteries can connect in parallel for larger capacity and longer power supporting duration requirements.

2.1 Product Features

- 1) The whole module is non-toxic, non-polluting, and environmentally friendly.
- 2) Cathode material is made from LiFePO₄ with safety performance and long cycle life.
- 3) Battery management system (BMS) has protection functions including over-discharge, over-charge, over-current and high & low temperature.
- 4) The system can automatically manage charge and discharge state and balance current and voltage of each cell.
- 5) Flexible configuration, multiple battery modules can be in parallel for expanding capacity and power.
- 6) Adopted self-cooling mode rapidly reduced system entire noise.
- 7) The module has less self-discharge, up to 6 months without charging it on shelf, no memory effect, excellent performance of shallow charge and discharge.
- 8) Battery module communication address auto networking, easy maintenance, support remotely monitoring and upgrade the firmware.
- 9) High-power density: flat design, floor-mounted, saving installation space.

2.2 Product Overview

This section details the interface functions of the front and side panel.

2.2.1 AI-W5.1 System Product Interface

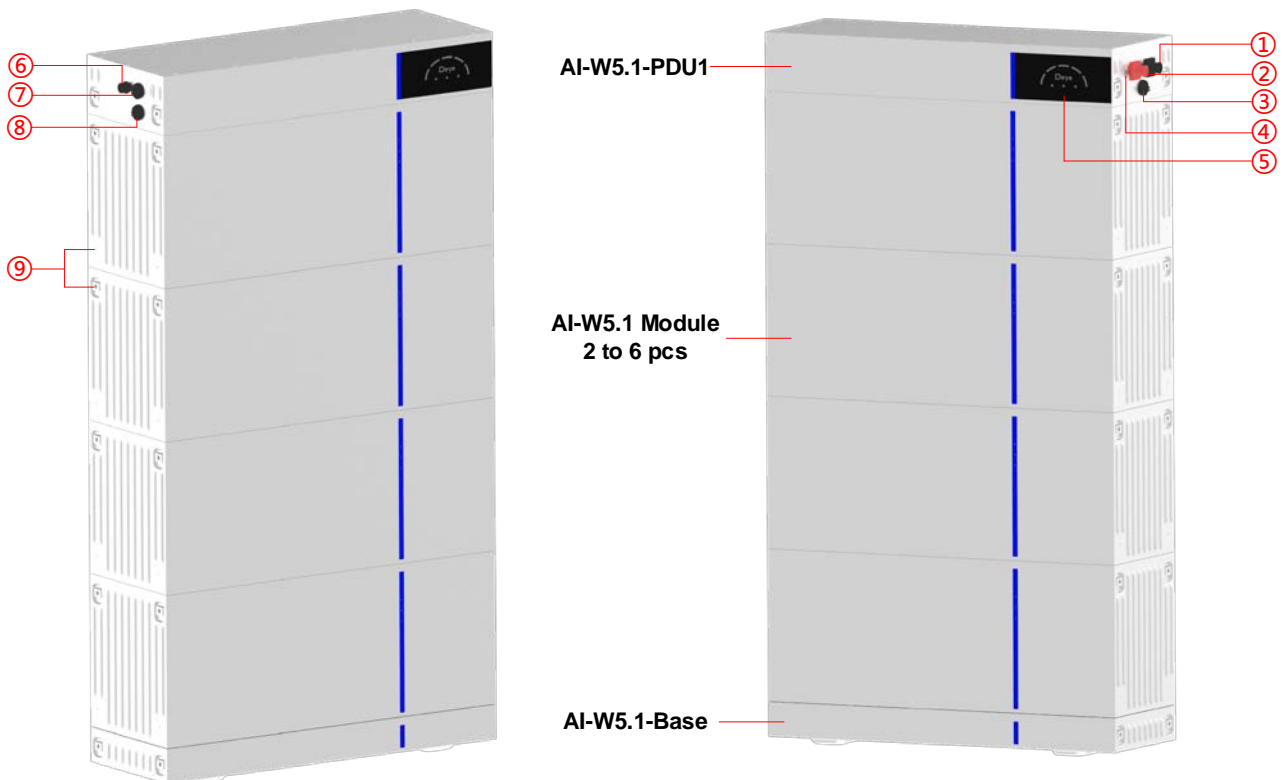

1. Battery negative	6. Wi-Fi module port
2. Battery positive	7. Inverter CAN/RS485 port PCS

3. Parallel communication port OUT	8. Parallel communication port IN
4. Power switch	9. Upper and lower fixing plate position
5. System state indicator	

Battery negative P-

The battery system charge and discharge negative port.

Battery positive P+

The battery system charge and discharge positive port.

OUT port

Parallel Communication Terminal: (RJ45 port) Connect "IN" Terminal of next battery for communication between multiple parallel batteries.

Definition of Out Port Pin

No.	Out Port Pin
1	CANL
2	CANH
3	DO+
4	DO-
5	DO-
6	DO+
7	CANH
8	CANL



Power Switch POWER

Power Switch: to turn ON/OFF the BMS of the entire battery system.

System state indicator

Indicates the operating status of the entire battery system, include SOC, RUN, ALARM, and ERROR. Refer to introduction in 2.2.2.

Wi-Fi module port

The data acquisition stick (Wi-Fi) mainly collects and records the working state of the battery system for long-term and effective monitoring of the battery system, and receives various information of the system from the battery end. The data is sent wirelessly to the monitoring platform, and the real-time status and historical data of the battery system can be presented in the form of graphs, which is intuitive, clear, and easy to understand.

PCS port

Inverter communication terminal: (RJ45 port) follow the CAN protocol (baud rate: 500K), used to output battery information to the inverter.

Definition of PCS Port Pin

No.	PCS Port Pin
1	485-B
2	485-A
3	--
4	CANH
5	CANL
6	--
7	485-A
8	485-B



IN port

Parallel Communication Terminal: (RJ45 port) Connect "out" Terminal of Previous battery for communication between multiple parallel batteries.

Definition of IN Port Pin

No.	PCS Port Pin
1	CANL
2	CANH
3	DI+
4	DI-
5	DI-
6	DI+
7	CANH
8	CANL



Upper and lower fixing plate position

Use the fixing plate to secure the upper and lower layers together to prevent tilting and collapse, with two fixing plates on the left and right between each two layers.

BMS function:

Protection and Alarm	Management and Monitor
Charge/Discharge End	Intelligent Protect Mode
Charge Over Voltage	Intelligent Charge Mode
Discharge Under Voltage	Protect, Charge Current Limit
Charge/Discharge Over Current	Intelligent Protect Mode
High/Low Temperature(cell/BMS)	Intelligent Protect Mode
Short Circuit	Protect

2.2.2 AI-W5.1-PDU1 Interface



Front appearance

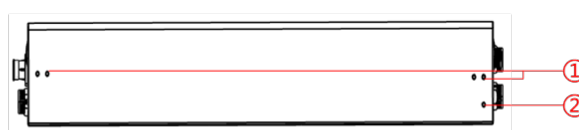

Back view

1. Wall fixing plate position

2. System earthing position

Wall fixing plate position

After installation, for the battery system fixed on the wall to prevent tilt.

System earthing position

Protective earthing for the battery system connecting to the PE.

LED Status Indicator Instructions:

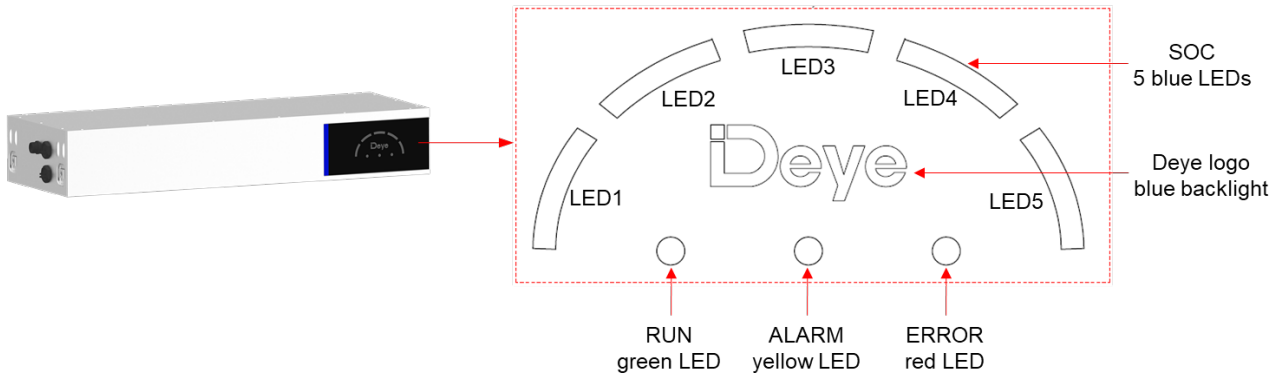

RUN LED: green, keep flashing when power switch is on.

ALARM LED: yellow, flashes when battery has alarm.

ERROR LED: red, long bright if battery is protected.

SOC LED: 5 blue LEDs, battery capacity indicator, each light represents 20% capacity.

Condition	RUN	ALARM	Error	LED1	LED 2	LED 3	LED 4	LED 5
Power off	off							
Charge	● Blink	● Blink if Alarm Exists	off	● Show SOC & highest LED blink				
Discharge or Idle			off	● Show SOC & long bright				
Alarm		● Blink	off	● Other LEDs are same as above				
System error/Protect		off	● long bright	Other LEDs are same as above				
Upgrade	Blink Fastly							
Critical Error	Blink Slowly							

2.2.3 AI-W5.1 Module Interface

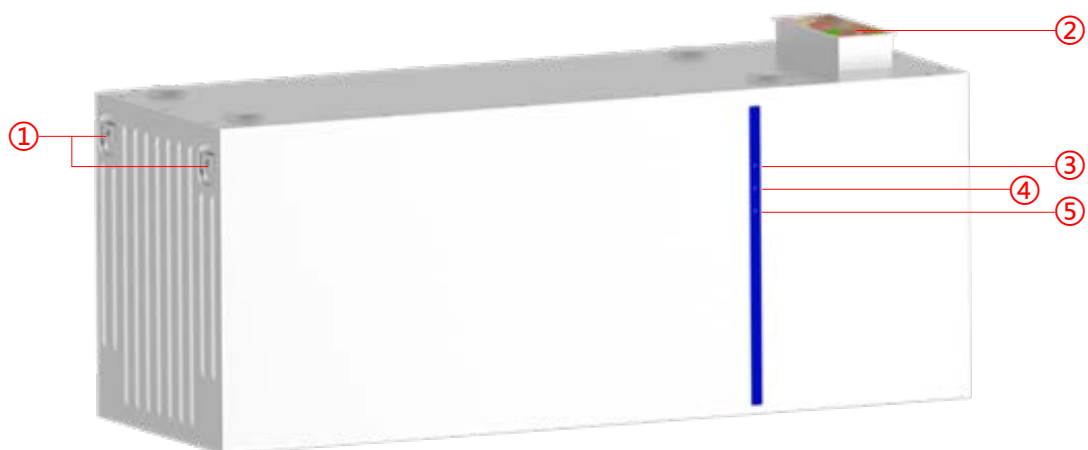

1. Movable handle handling position, Upper and lower fixing plate position	4. ALARM LED
2. Battery module dock terminals	5. ERROR LED
3. RUN LED	

RUN LED: green, keep flashing when the power switch is on.

ALARM LED: yellow, flashes when battery has alarm.

ERROR LED: red, long bright if battery is protected.

2.2.4 AI-W5.1-Base Interface



1. Upper and lower fixing plate position	2. Battery module dock terminals
--	----------------------------------

2.3 System Technical Data

Main Parameter	AI-W5.1				
Battery Chemistry	LiFePO4				
Battery Module Energy (kWh)	5.12				
Battery Module Voltage (V)	51.2				
Battery Module Capacity (Ah)	100				
Battery Module Quantity	2	3	4	5	6
Nominal Voltage (V)	51.2				
Operating Voltage(V)	43.2~57.6				
Energy (kWh)	10.24	15.36	20.48	25.6	30.72

Usable Energy (kWh) [1]	9.2	13.8	18.4	23.0	27.6
Charge/Discharge Current (A)	Recommend [2]	100	150	200	200
	Max. [2]	180	210	240	250
	Peak(10s,25°C)	270	315	360	360
Other Parameter					
Recommend Depth of Discharge	90%				
System Dimension (W/D/H, mm)	720*255*770	720*255*1055	720*255*1340	720*255*1625	720*255*1910
System Weight (kg)	124	177	230	283	336
Master LED Indicator	5LED(SOC:20%~100%), 3LED (working, alarming, protecting)				
IP Rating of Enclosure	IP65				
Operating Temperature	Charge: 0~55°C / Discharge: -20°C~55°C				
Storage Temperature	-20°C~35°C				
Humidity	5%~95%				
Altitude	≤2000m				
Installation	Floor-Mounted				
Communication Port	CAN2.0, RS485				
Certification	IEC62619, CE, VDE2510-10, CEI 0-21, UN38.3				
Battery PDU1	720*255*110(W/D/H, mm), 10kg				
Battery Module	720*255*285(W/D/H, mm), 53kg				
Battery Base	720*255*85(W/D/H, mm), 8kg				

[1] DC Usable Energy, test conditions: 90% DOD, 0.5C charge & discharge at 25°C. System usable energy may vary due to system configuration parameters.

[2] The current is affected by temperature and SOC.

2.4 Battery Module Data (AI-W5.1)

Main Parameter	AI-W5.1	
Battery Chemistry	LiFePO4	
Battery Module Energy (kWh)	5.12	
Battery Module Voltage (V)	51.2	
Battery Module Capacity (Ah)	100	
Battery Module Serial Cell QTY.	16	
Nominal Voltage (V)	51.2	
Operating Voltage(V)	43.2~57.6	
Charge/Discharge Current (A)	Recommend [1]	50
	Max. [1]	100
	Peak(10s,25°C)	150
Other Parameter		
Recommend Depth of Discharge	90%	
Battery Module Dimension (W/D/H, mm)	720*255*285	
Battery Module Weight (kg)	53	
Master LED Indicator	3LED (working, alarming, protecting)	
IP Rating of Enclosure	IP65	

Operating Temperature	Charge: 0~55℃ / Discharge: -20℃~55℃
Storage Temperature	-20℃~35℃
Humidity	5%~95%
Altitude	≤2000m
Cycle Life	≥6000(25℃±2℃,0.5C/0.5C,70%EOL)
Installation	Floor-Mounted
Communication Port	CAN2.0, RS485
Energy Throughput	16MWh(@70%EOL)
Certification	IEC62619, CE, VDE2510-10, CEI 0-21, UN38.3

[1] The current is affected by temperature and SOC.

2.5 Product application solutions

The following illustration shows basic application of this battery. It also includes following devices to have a complete running system.

- Generator or Utility
- PV modules
- Low voltage Hybrid Inverters (Charge & Discharge)

Consult with your system integrator for other possible system architectures depending on your requirements.

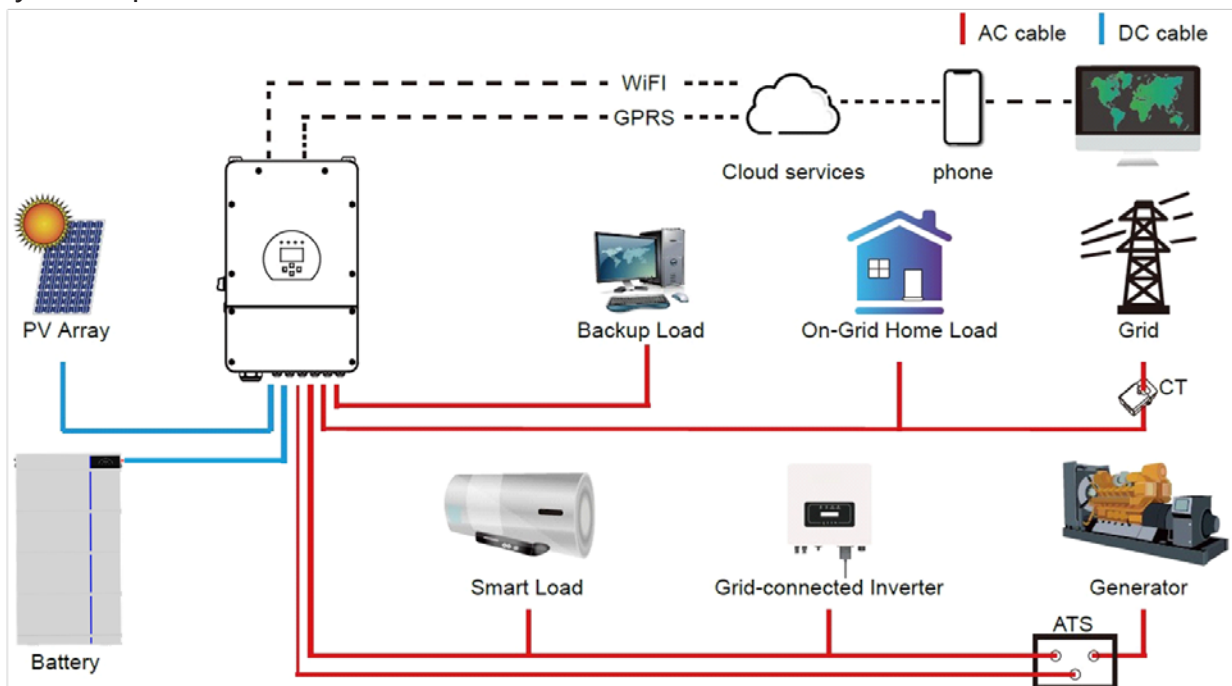







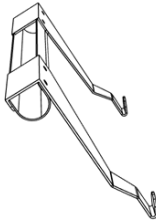

The picture is only an effect picture, please refer to the actual product, the final interpretation right belongs to DEYE.

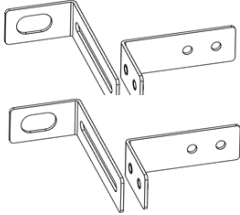
3 Parts List

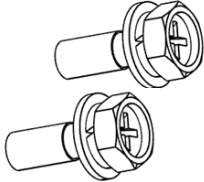
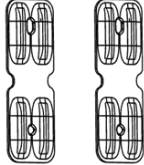
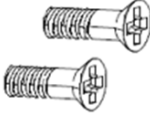
Check the equipment before installation. Please make sure nothing is damaged in the package. You should have received the items in the following package.

3.1 System Power Distribute Unit packaging box Parts List

 <p>PDU1 x1</p>	 <p>Movable handle x2</p>	 <p>Ground wire 2m x1</p>	 <p>Wall fixing plate x2 sets</p>
 <p>Base x1</p>	 <p>Expansion screws M6*100 x2</p>	 <p>Wall fixing plate mounting screws M4*12 x8</p>	 <p>Upper and lower fixing plate x4</p>
 <p>Upper and lower fixing plate screws M4*12 x8</p>	 <p>User Manual x1</p>	 <p>Wi-fi module x1</p>	 <p>AI-W5.1-Pcable 1.5m x1 set (Optional)</p>

3.2 Li-ion Battery Pack packaging box Parts List

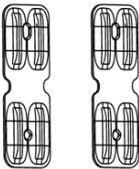
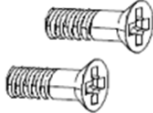
 <p>Battery Pack x1</p>	 <p>Upper and lower fixing plate x4</p>	 <p>Upper and lower fixing plate screws M4*12 x8</p>
--	--	---

4 Preparations for Installation

4.1 Explanation of Symbol



DANGER/HIGH VOLTAGE INSIDE



CAUTION:

- Do not disassemble or alter the battery in any way.
- Do not use the battery for purposes not described in its documentation.
- Do not drop, strike, puncture, or step on the battery.
- In case of electrolyte leakage, keep leaked electrolyte away from contact with eyes or skin, immediately clean with water and seek help from a doctor.
- Do not put the battery into a fire. Do not use it or leave it in a place near fire, heaters, or high temperature sources.
- Do not submerge the battery in water, or expose it to moisture.
- Do not allow the terminals to contact exposed wire or metal.
- The battery is heavy and can cause injury if not handled safely.
- Keep out of reach of children or animals.



No direct sunlight!



Keep away from heat!

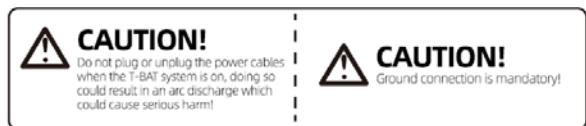

4.2 Tools

These tools are required to install the battery.



Torque Screwdriver



Phillips Screwdriver



Hexagon Wrench



Phillips Screwdriver



Slotted Screwdriver



Torque Wrench

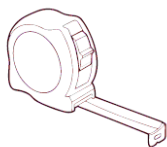

Tape Measure



Driller



Pencil or Marker

NOTE:

Use properly insulated tools to prevent accident tale electric shock or short circuits. If insulated tools are not available, cover the entire exposed metal surfaces of the available tools, except their tips, with electrical tape.

4.3 Safety Gear

It is recommended to wear the following safety gear when dealing with the battery pack.



Safety gloves



Safety goggles



Safety shoes

5 Installation instructions

5.1 Installation Precaution

Lithium battery is designed for outdoor use (IP65). But please avoid direct sunlight, rain exposure, snow laying up during installation and operation.

Make sure that the installation location meets the following conditions:

- ◇ The installation area shall avoid of direct sunlight.
- ◇ The floor and walls are completely water proof.
- ◇ The wall is flat and level.
- ◇ There are no flammable or explosive materials.
- ◇ The ambient temperature is within the range from -20°C to 50°C. Not in the cool air directly.
- ◇ There is minimal dust and dirt in the area.
- ◇ The distance from heat source is more than 2 meters.
- ◇ The distance from air outlet of inverter is more than 0.5 meters.
- ◇ Do not place at a children or pet touchable area.
- ◇ There are no mandatory ventilation requirements for battery module, but please avoid of installation in confined area. Do not cover or wrap the battery case or cabinet.
- ◇ The aeration shall avoid of high salinity, humidity, or temperature. Not in environment of precipitation or humidity (>95%).
- ◇ Not higher than altitude of about 2000 meters above sea level.

**CAUTION**

Cleaning. Before installing and powering up the system, dust and iron filings must be removed to keep the environment clean. The system cannot be installed in desert areas without a shell to protect against sand.



CAUTION

Temperature. If the ambient temperature is outside the operating range, the battery pack stops operating to protect itself. The optimal temperature range for the battery pack to operate is 15°C to 35°C.

Frequent exposure to harsh temperatures may deteriorate the performance and life of the battery pack.



CAUTION

Fire extinguisher system. For safety, it is best to have a fire extinguisher system. The fire protection system needs to be checked regularly to keep it in normal condition. For use and maintenance requirements, follow local fire equipment guidelines.



CAUTION

Grounding system. Before the battery is installed, it must be determined that the basement grounding point is stable and reliable. If the battery system is installed in a separate equipment compartment (such as a container), the grounding of the cabin must be stable and reliable.

The resistance of the grounding system is not less than 0.1Ω



CAUTION

Handling and placement. The weight of the single battery module is 53kg. If there is no handling tool, at least 2 persons must carry it.

The battery module must be installed by at least two persons using movable handles.

The PDU and Base are light to handle and place and can be installed by a single person.

5.2 Install the Battery



CAUTION

Remember that this battery is heavy! Please be careful when lifting out from the package.

The battery module must be installed by at least two persons using movable handles.

5.2.1 Selection of installation sites

It is necessary to choose the appropriate installation location site according to the requirements of 5.1.

Batteries should be installed in a clean flat place with no direct sunlight, away from water and fire sources, and at a suitable temperature. It is recommended that the height of the base is 300mm above the ground and can support 124kg to 336kg of the entire battery system. The installation location is recommended to meet the size requirements of the figure below:

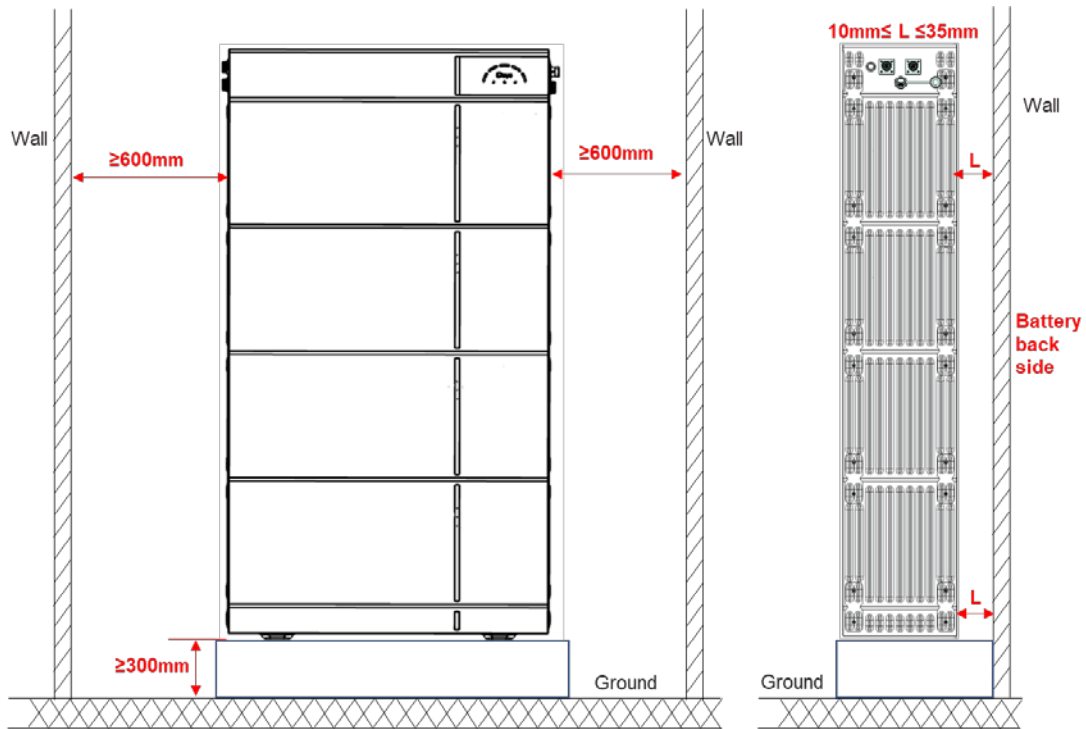

5.2.2 Unpacking order

First open the box of **System Power Distribute Unit**, take out the base and handle. The handle is used to carry the battery module, without the handle the battery module will be difficult to remove from the battery box.

5.2.3 Installation order

i. Put the installed base along the wall, and keep the distance of 10~35 mm between the wall and the base.

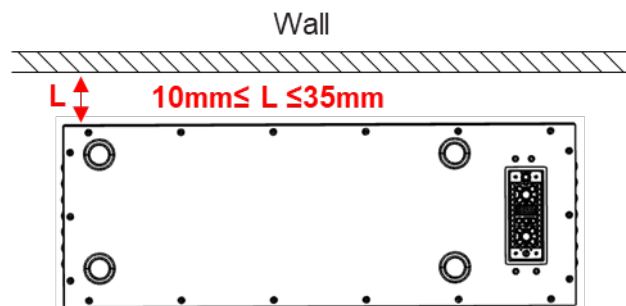

ii. Open the battery box, take a battery module out. Stick the two movable handles in the clasp on each side of the battery, easy for lifting. Put one battery module on the base. Insert the plug on the base into the port on the battery. Pay attention to the direction of the module to make sure that the blind-mating connectors of the module and the base are at the same side.

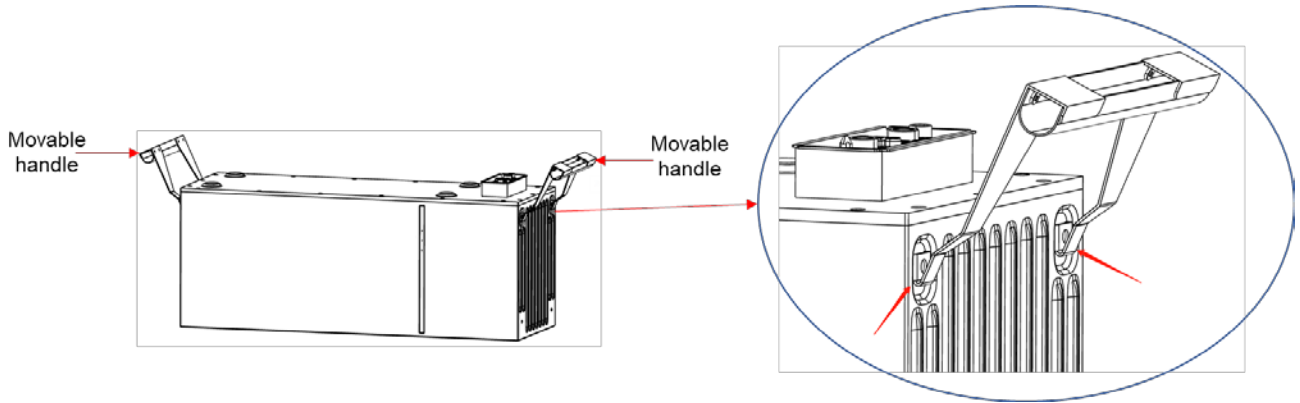

iii. Plug the upper battery module connector into the lower battery connector. Repeat the operations for other battery modules.

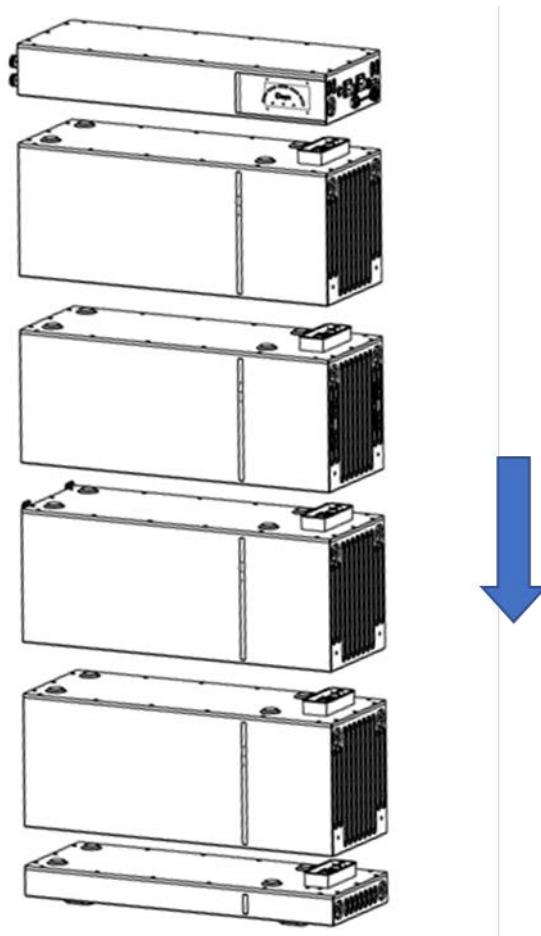

iv. Install the wall fixing plate (PDU part) to the PDU. To do this, follow the instructions below to install and tighten them on the back side of PDU (torque: 2 Nm).

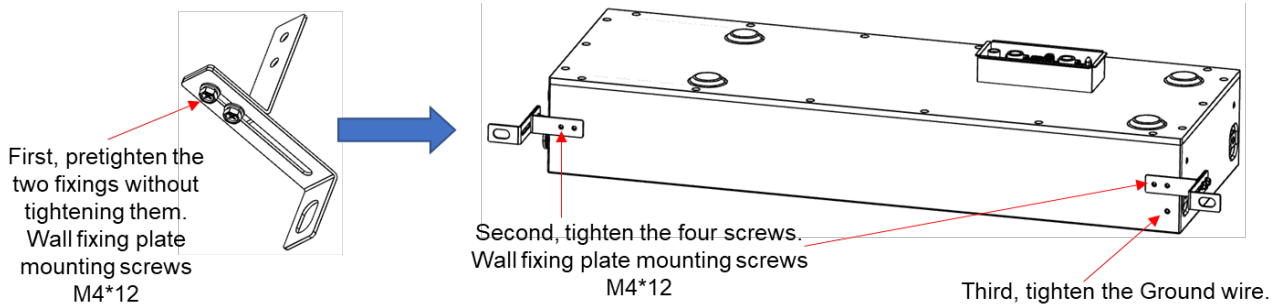

- v. After all battery modules are stacked, put the PDU on top of the battery modules.
- vi. Fix the connection between the battery module and the base, between battery modules, and between PDU and battery module with upper and lower fixing plate. To do this, insert the screws (M4x12) through the holes on them, using a Hexagon Wrench (2.5mm) and tighten them (torque: 2 Nm).

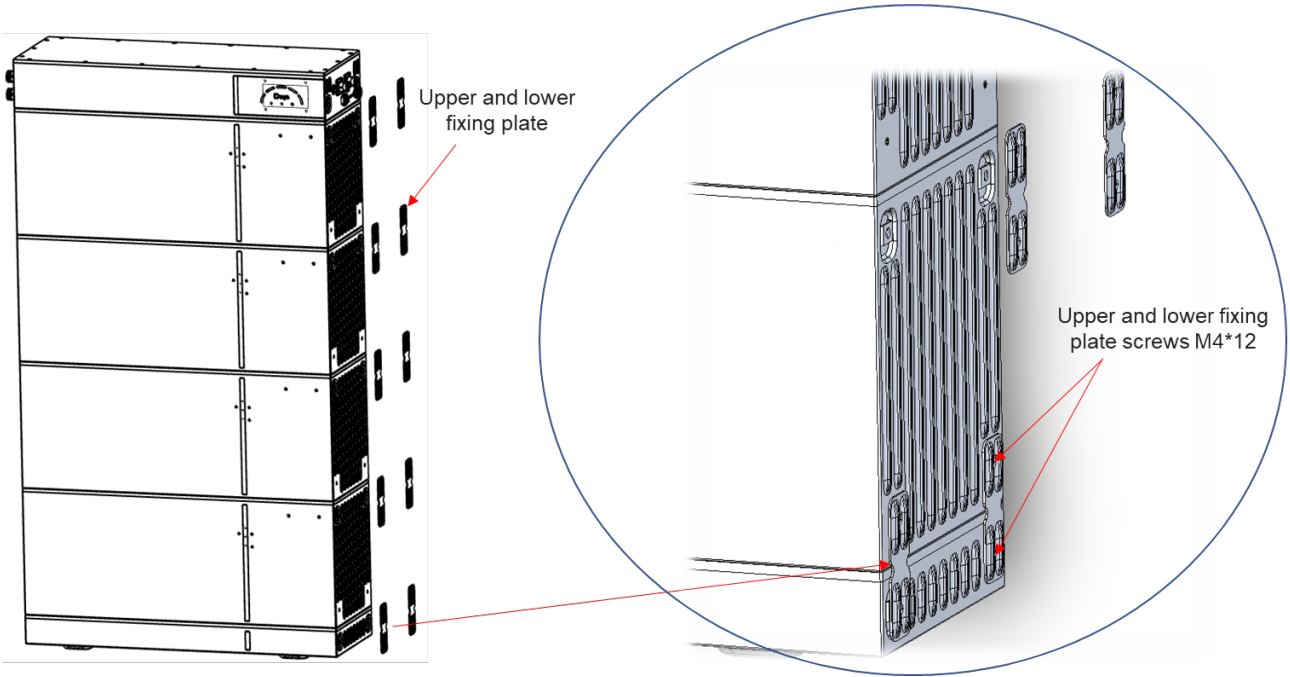

- vii. Hold the wall fixing plate (wall part) where it intends to be mounted on the wall and mark the position of the drill holes. Please pay attention that there may be power cables or other supply lines (e.g., gas or water) routed inside of the wall. Ensure that no lines are laid in the wall, which could be damaged when drilling holes.

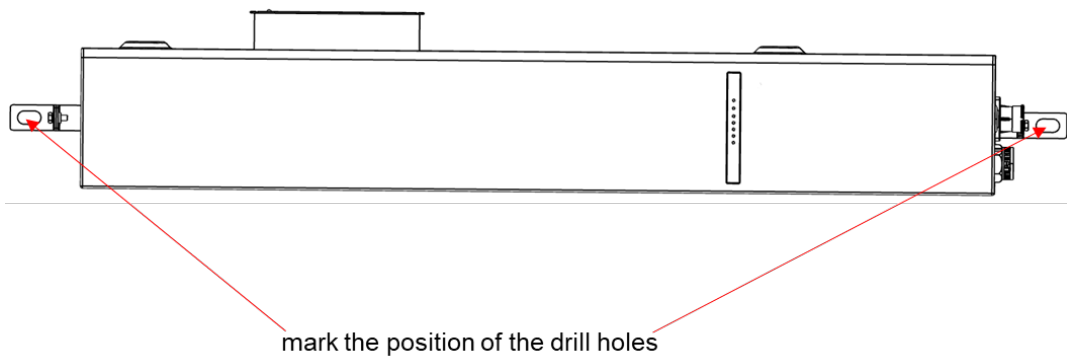

- viii. Set the wall fixing plate (wall part) aside and drill the marked holes. Choose the recommend drill head (10mm) to drill 2 holes on the wall, 100mm-110mm deep. Put the wall fixing plate (wall part) in front of the holes, then insert the expansion screw of M6*100 and tighten.

- ix. Fix the two hangers (wall part and PDU part) with M4X12 screws, using a cylinder screwdriver (10 mm) to tighten it (torque: 2 Nm).

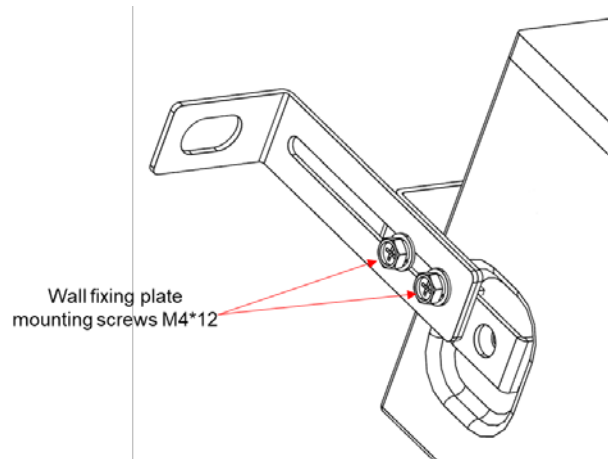

5.2.4 Wall-mounted method

Step 1

Use a marker to draw lines, determine the positions, and drill holes.

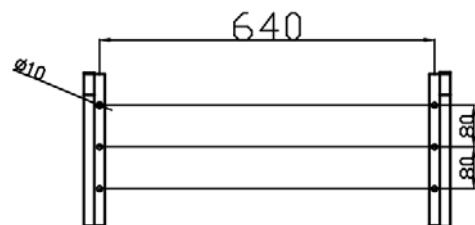

Hole size drawing

Step 2

Place the expansion screws into the holes, install the sheet metal support plate on the support, level the plate, and tighten the screws.

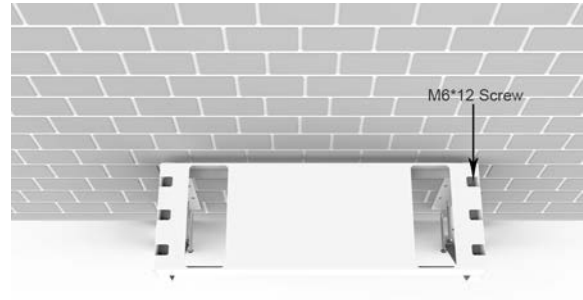
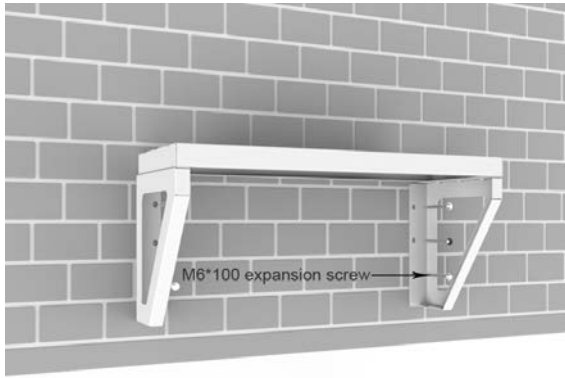

Step 3
Place the base on the sheet metal support plate.

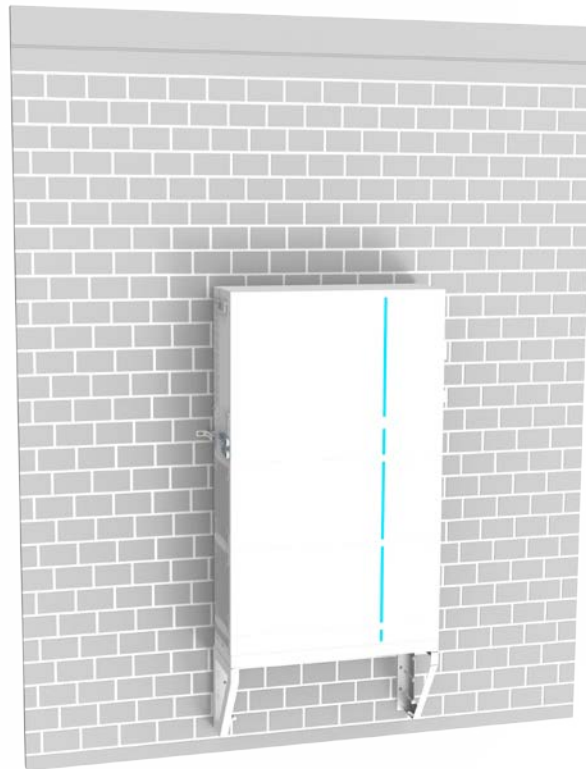

Step 4
After Step 3 finished, please refer to 5.2.3 Installation order (Floor-Mounted method) to complete the subsequent installation.

5.3 Electrical Connection

5.3.1 Single Battery System (It is suitable for scenarios where the inverter power \leq 12kW)



CAUTION

It should be noted that the maximum current of single battery system is 250A (inverter power must not exceed 12kW), exceeding 250A will cause heating of the connectors and cable, and in severe cases, it will cause a fire accident.

If the inverter power exceeds 12kW, the connection mode must be used **Multiple Battery System!**

Schematic diagram of connection of single battery system:

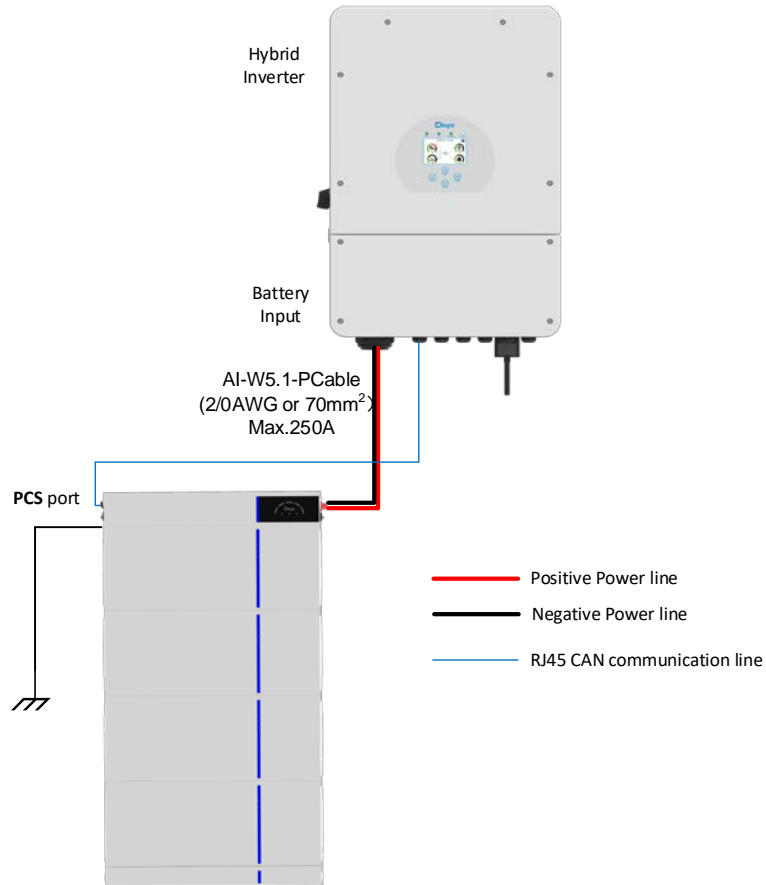

5.3.2 Multiple Battery System (It is suitable for scenarios where the inverter power \geq 12kW)

Schematic diagram of connection of Multiple batteries system:

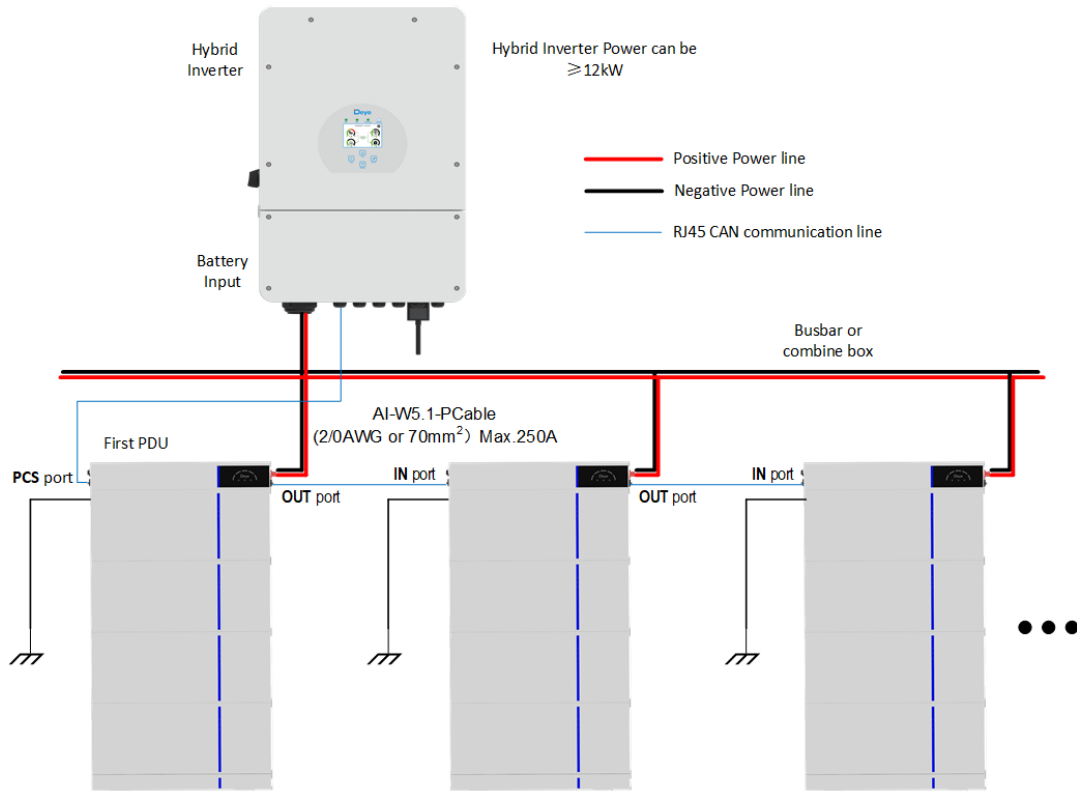

or larger capacity systems:

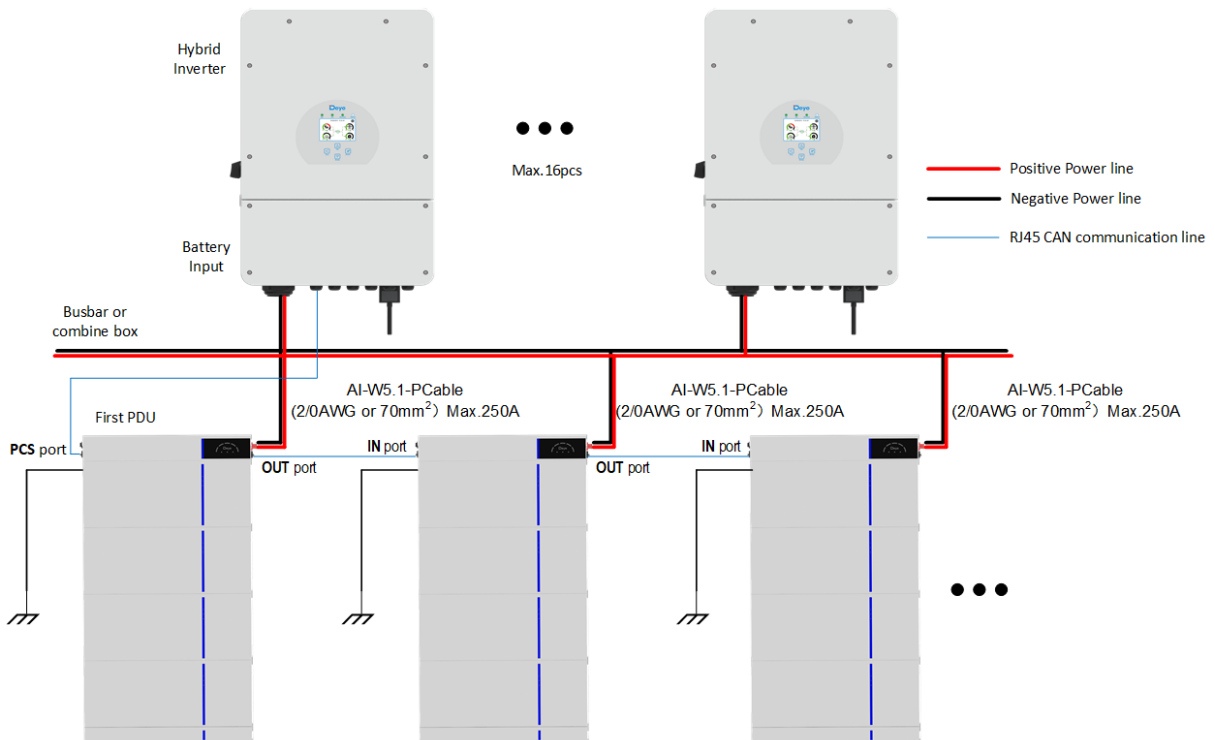

5.4 Visual Inspection of the Connection

After connecting the battery, check for:

- Use positive and negative cables correctly.
- Connection of the positive and negative terminals.
- All the bolts are tightened.
- Cables fixation and the appearance.
- The installation of the protecting cover.

5.5 Activate the Product

- A. Installation the AI-W5.1 battery as shown on chapter 5.2.
- B. Connect the wires according to chapter 5.3.
- C. Turn on all battery power in turn.

Start the Battery:

After installation, wiring, and configuration are completed, you must check all the connection. When the connections are correctly, and then press power button to activate the battery. The green working light on the front panel of the battery flashes, indicating that the battery system is normal.

6 Inspection, Cleaning and Maintenance

6.1 General Information

- The battery product is not fully charged. It is recommended that the installation be completed within 3 months after arrival;
- During the maintenance process, do not re-install the battery in the battery product. Otherwise, the performance of the battery will be reduced;
- It is forbidden to dismantle any battery in the battery product, and it is forbidden to dissect the battery;
- After the battery product is over-discharged, it is recommended to charge the battery within 48 hours. The battery product can also be charged in parallel. After the battery product is connected in parallel, the charger only needs to connect the output port of any product battery.
- Never attempt to open or dismantle the battery! The inside of the battery does not contain serviceable parts.
- Disconnect the Li-Ion battery from all loads and charging devices before performing cleaning and maintenance activities.
- Place the enclosed protective caps over the terminals before cleaning and maintenance activities to avoid the risk of contacting the terminals.

6.2 Inspection

- Inspect for loose and/or damaged wiring and contacts, cracks, deformations, leakage, or damage of any other kind. If damage to the battery is found, it must be replaced. Do not attempt to charge or use a damaged battery. Do not touch the liquid from a ruptured battery.

- Regularly check the battery's state of charge. Lithium Iron Phosphate batteries will slowly self-discharge when not in use or whilst in storage.
- Consider replacing the battery with a new one if you note either of the following conditions:
 - The battery run time drops below 70% of the original run time.
 - The battery charge time increases significantly.

6.3 Cleaning

If necessary, clean the Li-Ion battery with a soft, dry cloth. Never use liquids, solvents, or abrasives to clean the Li-Ion battery.

6.4 Maintenance

The Li-Ion battery is maintenance free. Charge the battery to approximately > 80% of its capacity at least once every year to preserve the battery's capacity.

6.5 Storage

- The battery product should be stored in a dry, cool, and cool environment;
- Generally, the maximum storage period at room temperature is 6 months. When the battery is stored over 6 months, it is recommended to check the battery voltage. If the voltage is higher than 51.2V, it can continue to store the battery. In addition, it is needed to check the voltage at least once a month until the voltage is lower than 51.2V. When the voltage of the battery is lower than 51.2V, it must to be charged according to the charging strategy.
- The charging strategy is as follows: discharge the battery to the cutoff voltage with 0.2C(20A) current, and then charge with 0.2C(20A) current for about 3 hours. Keep the SOC of the battery at 40%-60% when stored;
- When the battery product is stored, the source of ignition or high temperature should be avoided and it should be kept away from explosive and flammable areas.

7 Troubleshooting

To determine the status of the battery system, users must use additional battery status monitoring software to examine the protection mode. Refer to the installation manual about using the monitoring software. Once the user knows the protection mode, refer to the following sections for solutions.

Table 7-1: Troubleshooting

Fault Type	Fault Generation condition	Possible Causes	Troubleshooting
BMS fault	The cell voltage sampling circuit is faulty. The cell temperature sampling circuit is	The welding point for cell voltage sampling is loose or disconnected. The voltage sampling terminal	Replace the battery.

	faulty	is disconnected. The fuse in the voltage sampling circuit is blown. The cell temperature sensor has failed.	
Electrochemical cell fault	The voltage of the cell is low or unbalanced.	Due to large self- discharge, the cell over discharges to below 2.0V after long term storage. The cell is damaged by external factors, and short circuits, pin-pricks, or crushing occur.	Replace the battery.
Overvoltage protection	The cell voltage is greater than 3.65 V in charging state. The battery voltage is greater than 58.4 V.	The busbar input voltage exceeds the normal value. Cells are not consistent. The capacity of some cells deteriorates too fast or the internal resistance of some cells is too high.	If the battery cannot be recovered due to protection against abnormality contact local engineers to rectify the fault.
Under voltage protection	The battery voltage is less than 40V. The minimum cell voltage is less than 2.5V	The mains power failure has lasted for a long time. Cells are not consistent. The capacity of some cells deteriorates too fast or the internal resistance of some cells is too high.	Same as above.
Charge or discharge high temperature protection	The maximum cell temperature is greater than 60°C	The battery ambient temperature is too high. There are abnormal heat sources around	Same as above.
Charge low temperature protection	The minimum cell temperature is less than 0°C	The battery ambient temperature is too low.	Same as above.
Discharge low temperature protection	The minimum cell temperature is less than -20°C	The battery ambient temperature is too low.	Same as above.

By checking the above data and sending the data to the service personnel of our company, the service personnel of our company will reply the corresponding solution after receiving

the data.

8 Battery recovery

Aluminum, copper, lithium, iron, and other metal materials are recovered from discarded LiFePO_4 batteries by advanced hydrometallurgical process, and the comprehensive recovery efficiency can reach 80%. The specific process steps are as follows:

8.1 Recovery process and steps of cathode materials

Aluminum foil as collector is amphoteric metal. Firstly, it is dissolved in NaOH alkali solution to make aluminum enter the solution in the form of NaAlO_2 . After filtration, the filtrate is neutralized with sulfuric acid solution and precipitated to obtain $\text{Al}(\text{OH})_3$. When the pH value is above 9.0, most of the aluminum precipitates, and the obtained $\text{Al}(\text{OH})_3$ can reach the level of chemical purity after analysis.

The filter residue is dissolved with sulfuric acid and hydrogen peroxide, so that lithium iron phosphate enters the solution in the form of $\text{Fe}_2(\text{SO}_4)_3$ and Li_2SO_4 , and is separated from carbon black and carbon coated on the surface of lithium iron phosphate. After filtration and separation, the pH value of the filtrate is adjusted with NaOH and ammonia water. First, iron is precipitated with $\text{Fe}(\text{OH})_3$, and the remaining solution is precipitated with saturated Na_2CO_3 solution at 90 °C.

Since FePO_4 is slightly dissolved in nitric acid, the filter residue is dissolved with nitric acid and hydrogen peroxide, which directly precipitates FePO_4 , separates impurities such as carbon black from acid solution, leaches $\text{Fe}(\text{OH})_3$ from filter residue respectively, and precipitates Li_2CO_3 with saturated Na_2CO_3 solution at 90 °C.

8.2 Recovery of anode materials

The recovery process of anode materials is relatively simple. After the separation of anode plates, the purity of copper can be more than 99%, which can be used for further refining electrolytic copper.

8.3 Recovery of diaphragm

The diaphragm material is mainly harmless, and has no recycling value.

8.4 List of recycling equipment

Automatic dismantling machine, pulverizes, wet gold pool, etc.

9 Transportation Requirements

The battery products should be transported after packaging and during the transportation process, severe vibration, impact, or extrusion should be prevented to prevent sun and rain. It can be transported using vehicles such as cars, trains, and ships.

Always check all applicable local, national, and international regulations before transporting a Lithium Iron Phosphate battery.

Transporting an end-of-life, damaged, or recalled battery may, in certain cases, be specially

limited or prohibited.

The transport of the Li-Ion battery falls under hazard class UN3480, class 9. For transport over water, air and land, the battery falls within packaging group PI965 Section I.

Use Class 9 Miscellaneous Dangerous Goods and UN Identification labels for transportation of lithium-ion batteries which are assigned Class 9. Refer to relevant transportation documents.



Figure 9-1: Class 9 Miscellaneous Dangerous Goods and UN Identification Label